

DOUBLE TOWER ASSEMBLY

* ALL CONNECTION POINTS ARE
NUMERICALLY AND COLOR
COORDINATED.

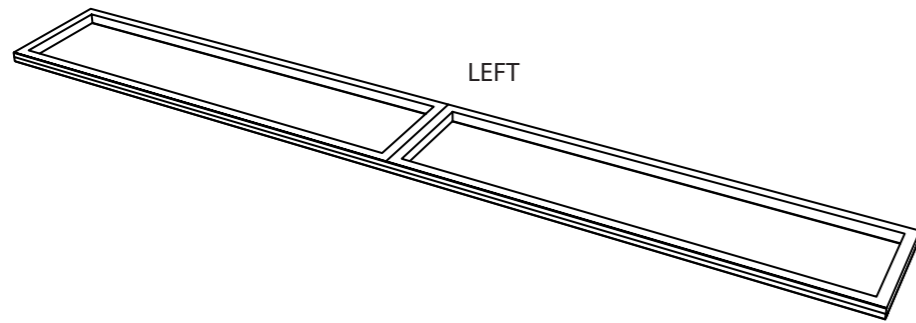

1. LIE HINGED PART LABELED "LEFT"
ON THE GROUND WITH THREADED
INSERTS FACING UP.

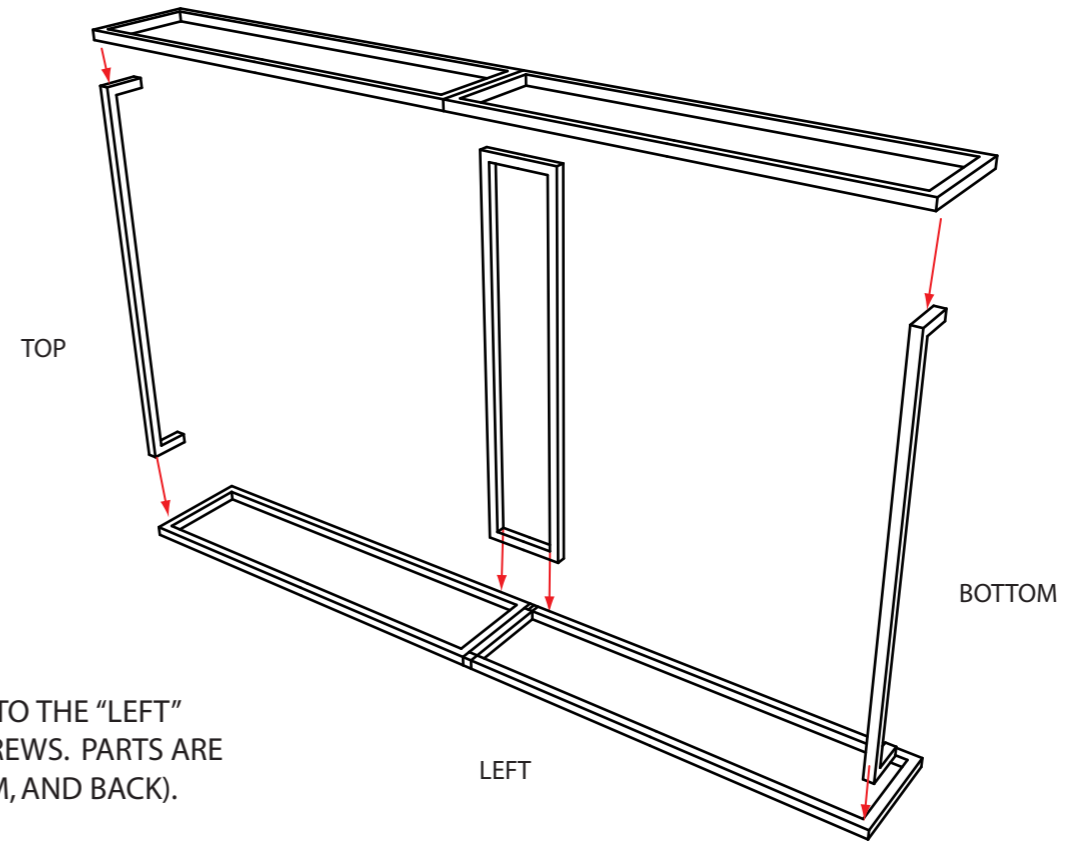

2. ATTACH CROSS PIECES TO THE "LEFT"
SIDE USING THUMB SCREWS. PARTS ARE
LABELED (TOP, BOTTOM, AND BACK).

3. LIE HINGED PART LABELED "RIGHT"
ON TOP OF THE ATTACHED CROSS
PIECES AND TIGHTEN THUMB
SCREWS. THEN ATTACH CENTER
BAR.

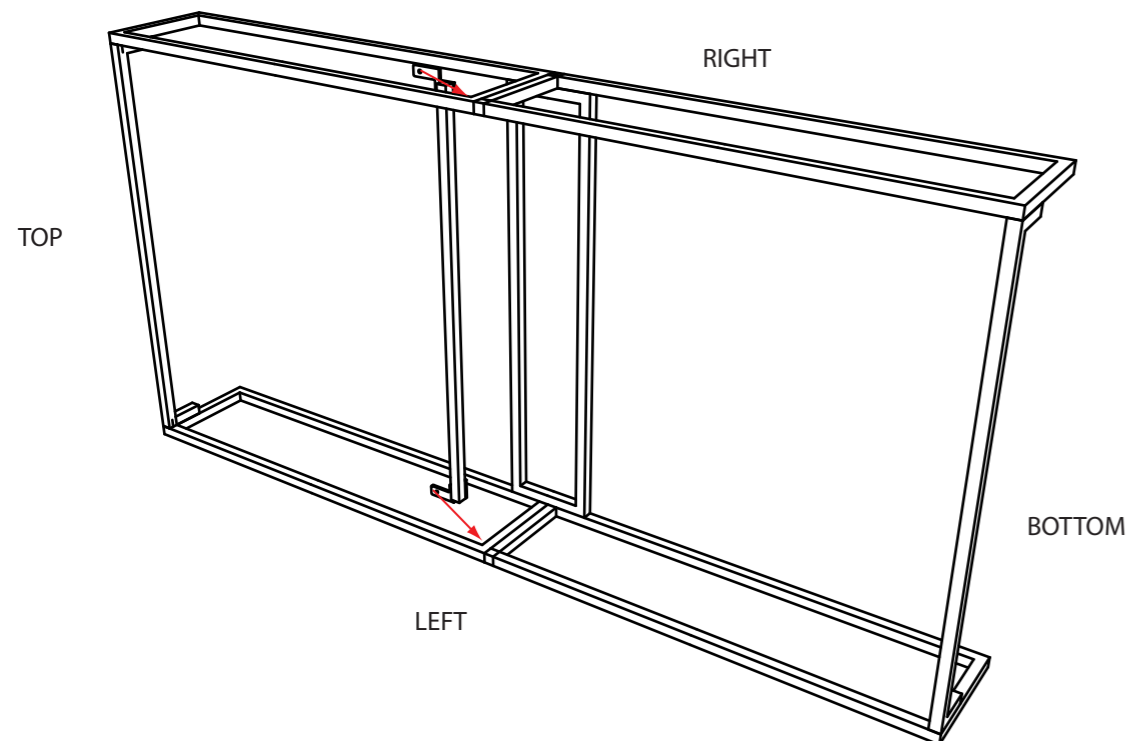

4. UNFOLD CENTER BEAM.

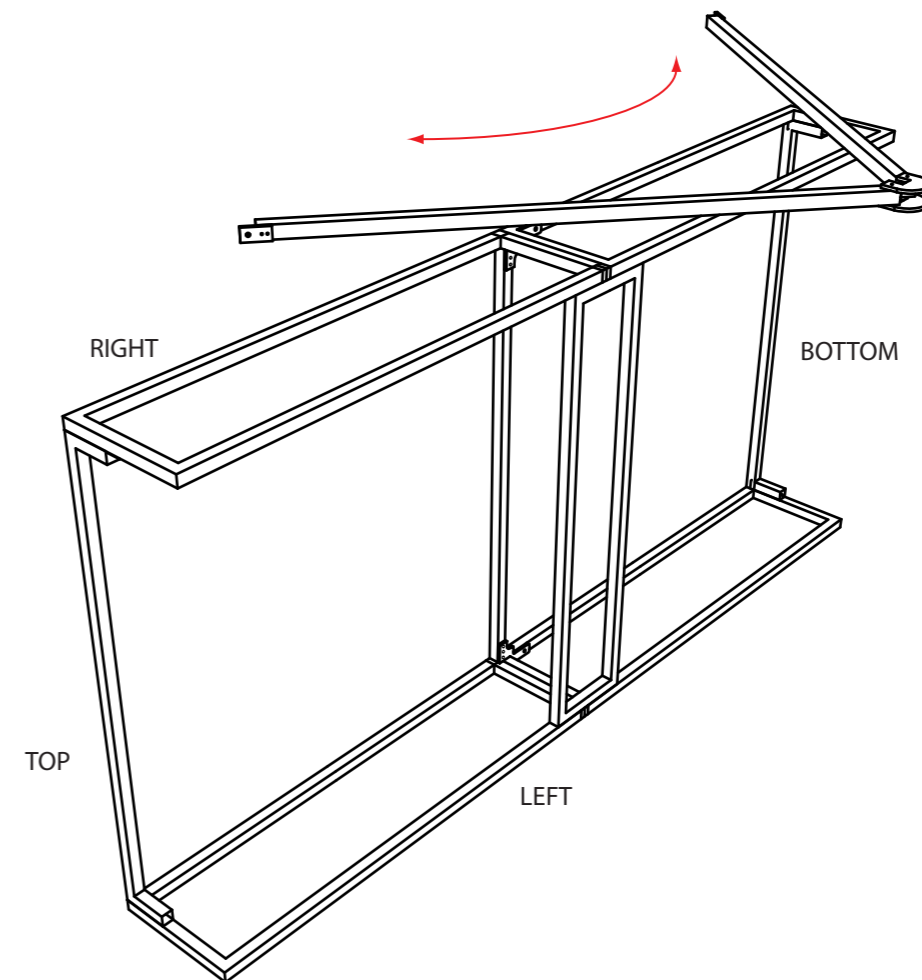

DOUBLE TOWER ASSEMBLY

* ALL CONNECTION POINTS ARE
NUMERICALLY AND COLOR
COORDINATED.

5. TIGHTEN THE CENTER BEAM'S
THUMB SCREWS, AND SLOWLY
STAND THE TOWER. THEN MOVE
IT INTO ITS DESIRED LOCATION.

