

AURA™

L I G H T B O X E S

Part Number	Qty for Step	Description
1	1	Base Plate
2	2	36" h Half Round Vertical extrusion
3	1	36" h Half Round Vertical extrusion
4	1	Base Plate
5	2	36" h Half Round Vertical extrusion
6	2	36" h Half Round Vertical extrusion
7	2	36" h Lower Horizontal extrusion
8	2	36" h Upper Horizontal extrusion
	2	Vertical Connector

Steps

- 1) Connect base plates [1 and 4] to vertical extrusions [2 and 5].
 - 2) Connect vertical extrusions [2 and 3] using vertical connector.
Repeat steps for vertical extrusions [5 & 6]
 - 3) Connect horizontal extrusions [7 and 8] between vertical extrusions [2, 3 and 5, 6] as shown.
 - 4) Place lights staggered inside the vertical extrusions making sure to run cords down through bottom opening.
- NOTE: Lights are pigtailed together in two's.
- 5) Attach Header to Sintra Cap and place atop assembled lightbox.

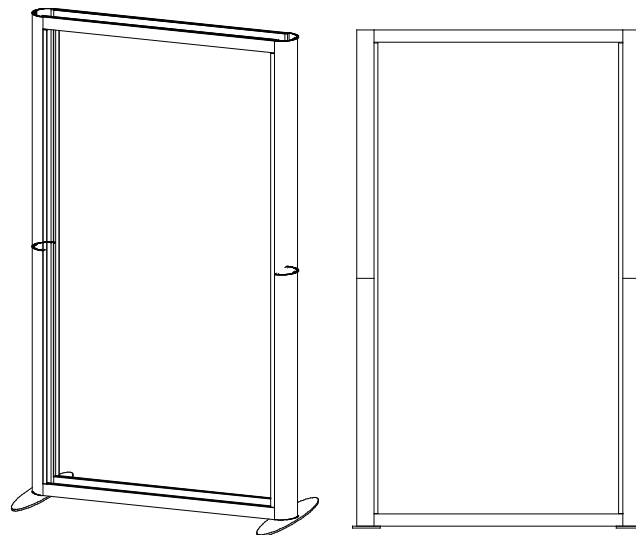
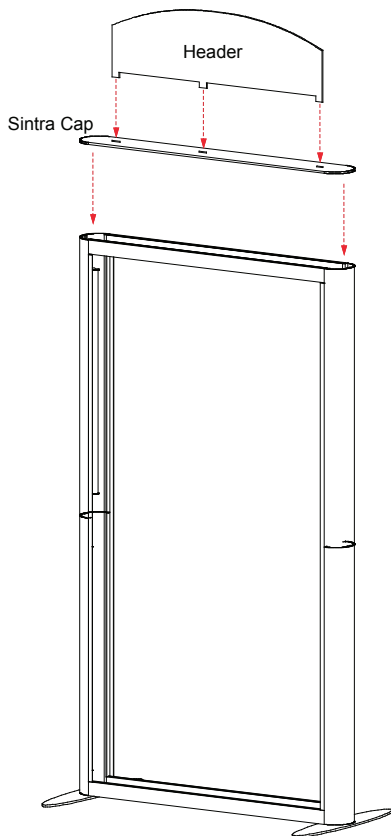
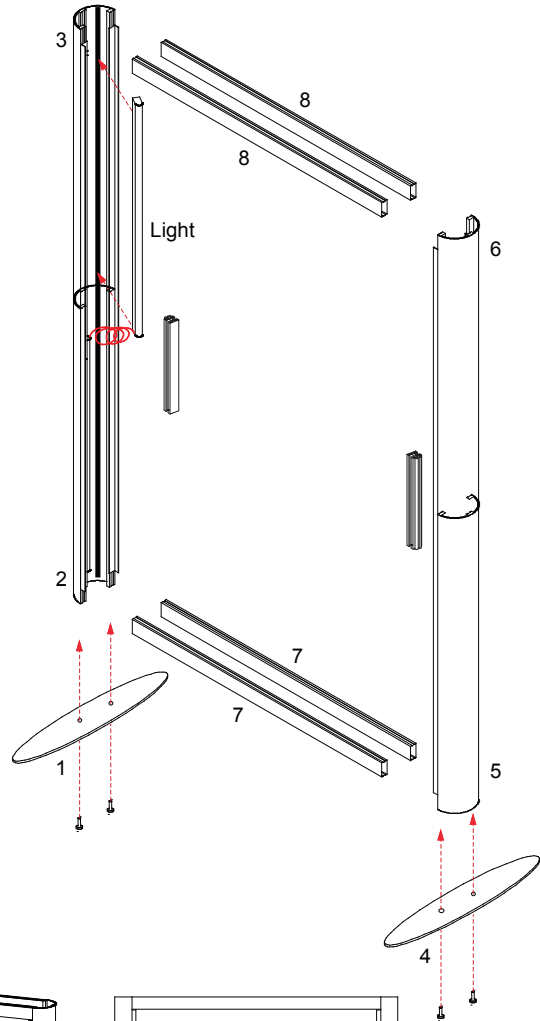

WHEN DISASSEMBLING ALUMINUM EXTRUSION, TIGHTEN ALL SETSCREWS AND LOCKS TO PREVENT LOSS DURING SHIPPING