

pulse monitor stand

PC-MK-01

The pulse monitor stand is an excellent addition to a variety of backwall displays and exhibits. Use this sturdy, stand alone kiosk in a variety of situations to display your multimedia messages.

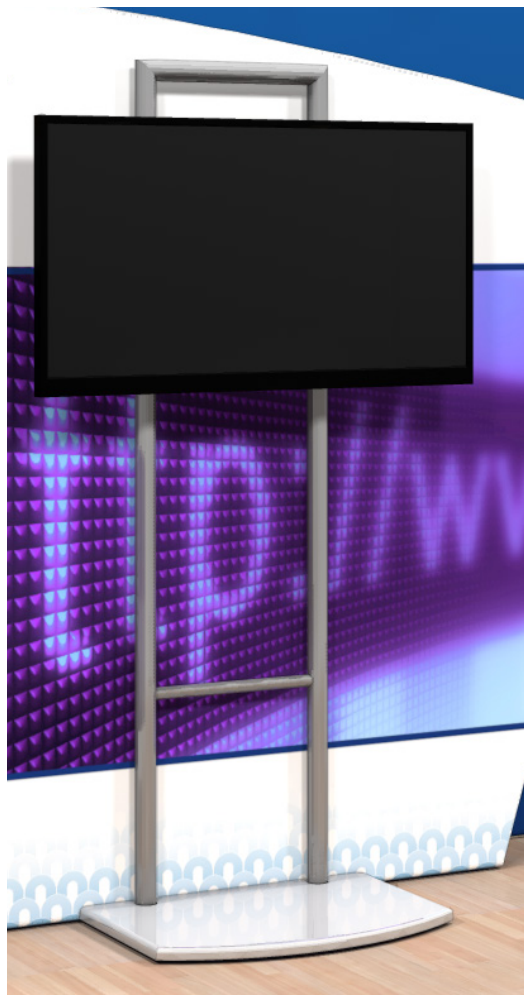

features and benefits:

- State-of-the-art snap button aluminum structure
- Frame constructed of 30mm and 50mm lightweight aluminum tubes
- Choose from four laminate base colors
- Brushed silver finish on exposed tube
- Easy step-by-step instructions
- Lifetime warranty on hardware against manufacturer defects

dimensions:

Hardware	Shipping
Assembled unit: 30"w x 78.38"h x 23.6"d 762mm(w) x 1990mm(h) x 600mm(d)	Shipping dimensions - ships in 1 case: WMC-12x6 case: 52"l x 30"w x 15"h 1320.8mm(l) x 762mm(w) x 381mm(h) Approximate shipping weight (entire kit): 70 lbs / 31.75 kgs

additional information:

Monitor mount holds max weight
50 lbs / 22.7 kgs

Monitor mount holds max size
40" / 1016mm

Base color options:



silver



black



mahogany



natural

nimlok

pulse

Parts included	
Part Label	Qty
Upper frame	x1
Lower frame	x1
Joiner	x4
Base plates	x2
Base	x1
Monitor bracket	x1

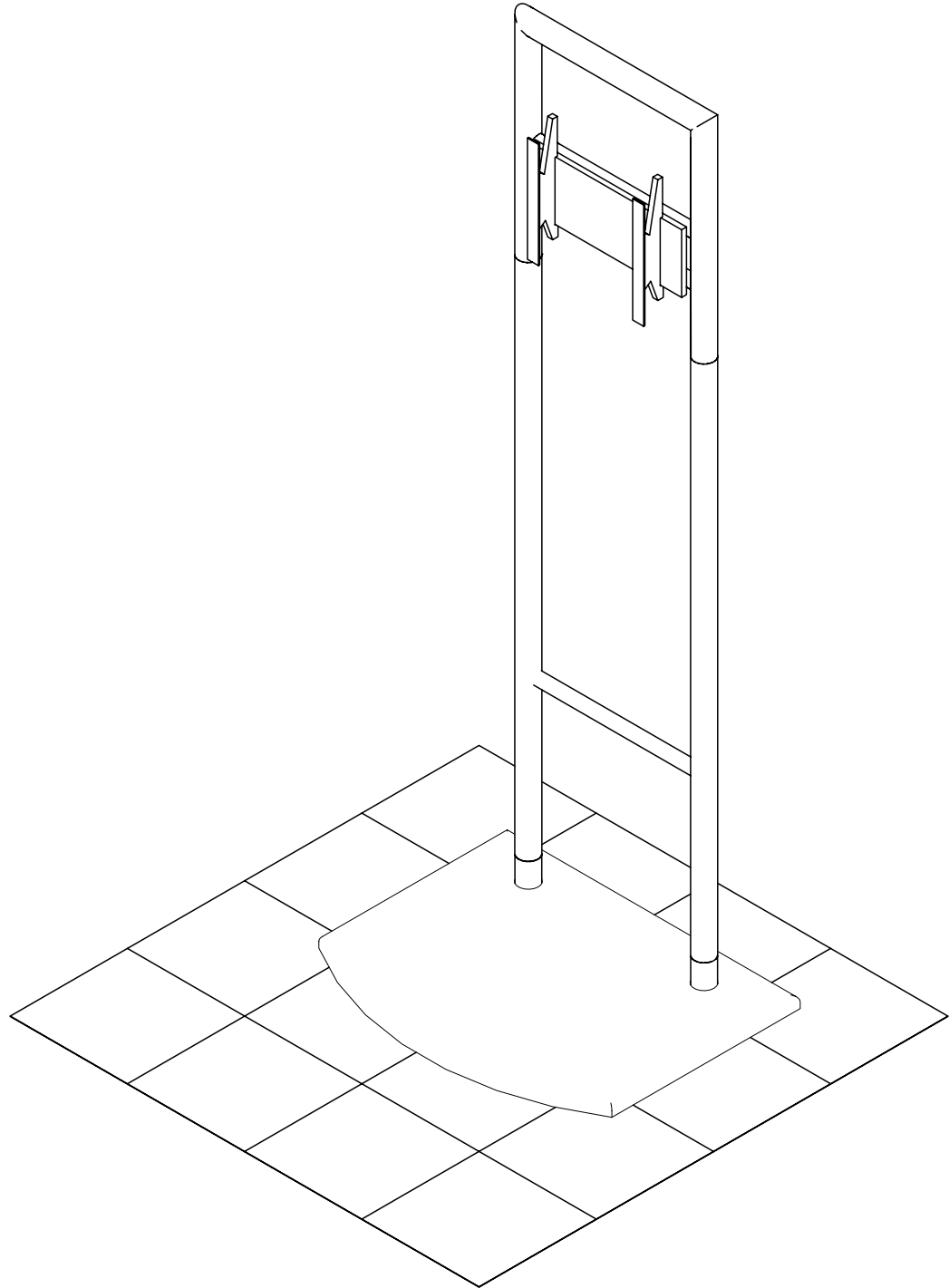
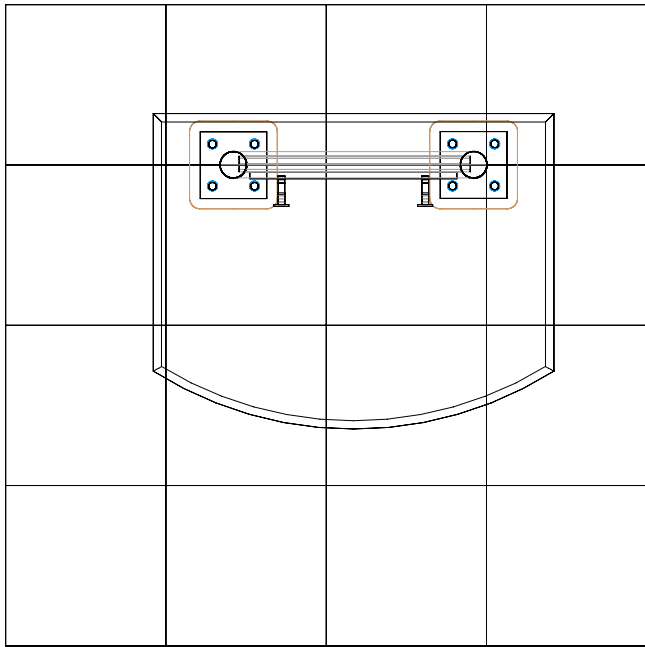

Step 1.

Connect the plates to the base using four screws per plate as shown in the attachment detail below. Assure holes on tubing are facing inward.

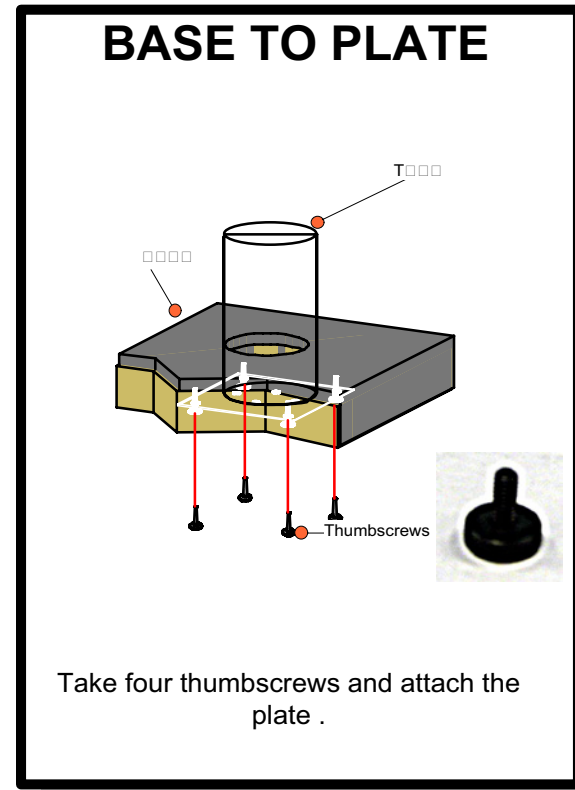
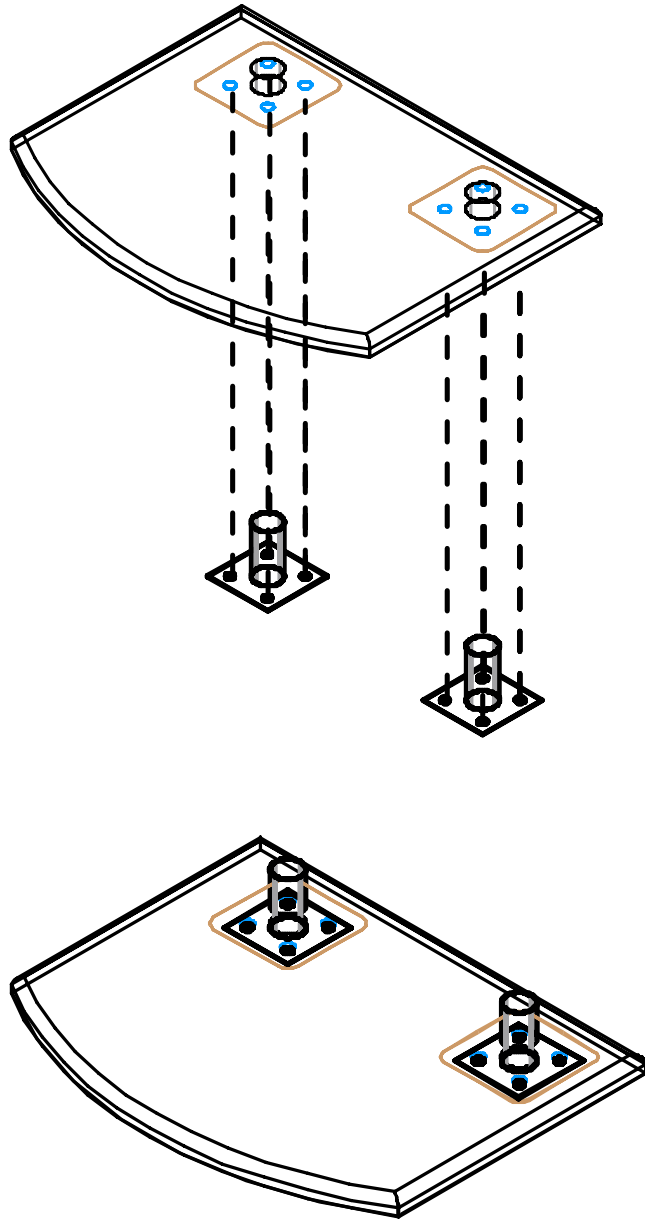

Step 2.

Attach the lower frame to the base plates at points 1A and 2A following the labels. Use the joiner to connect as shown in the attachment detail below. Attach the upper frame to the lower frame at points 3A and 4A following the labels. Use the joiner to connect as shown in the attachment detail below.

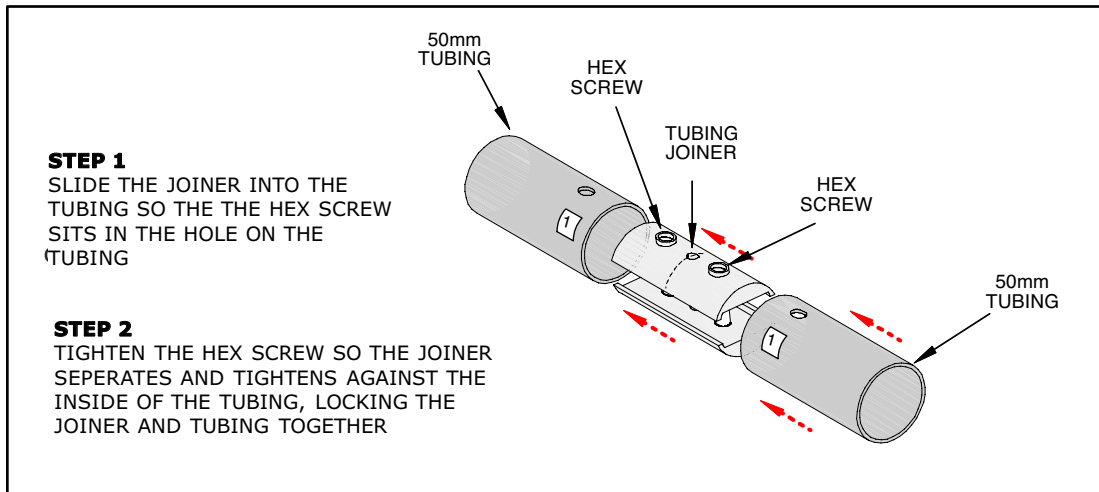
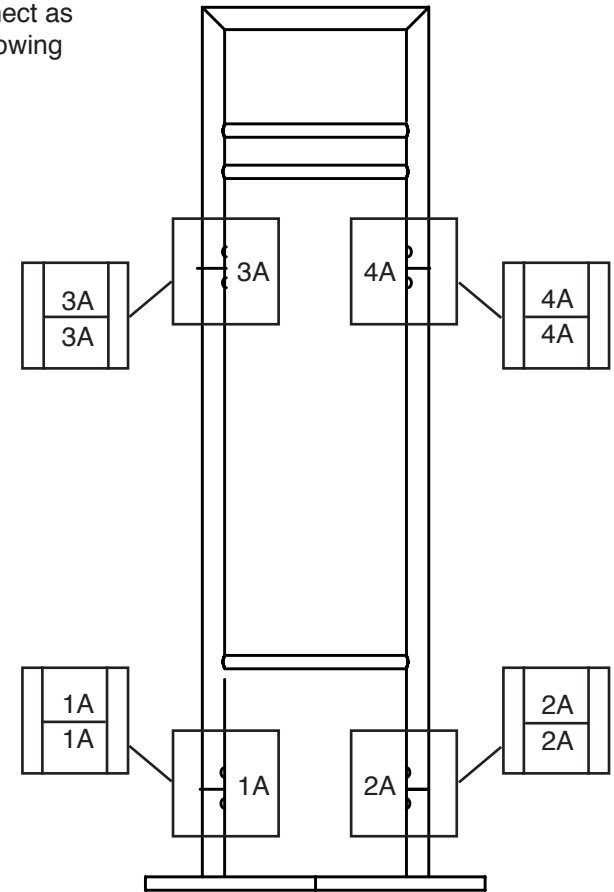
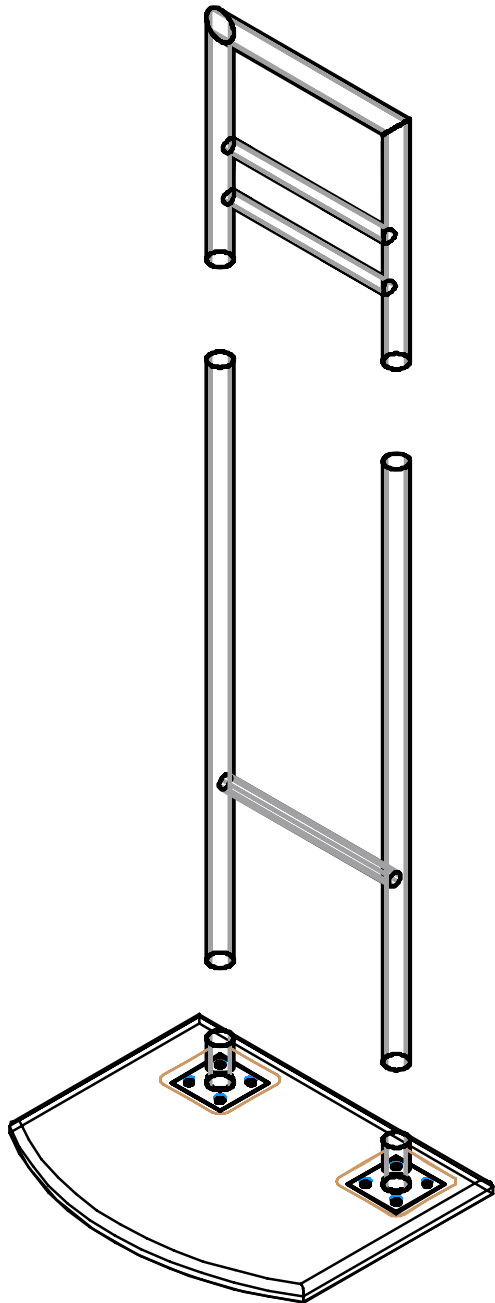

Step 3.

To attach the monitor mount, put square head bolts through the back of the pre-drilled tube. Slide monitor mount onto bolts and secure with wingnuts. Position mount where desired.

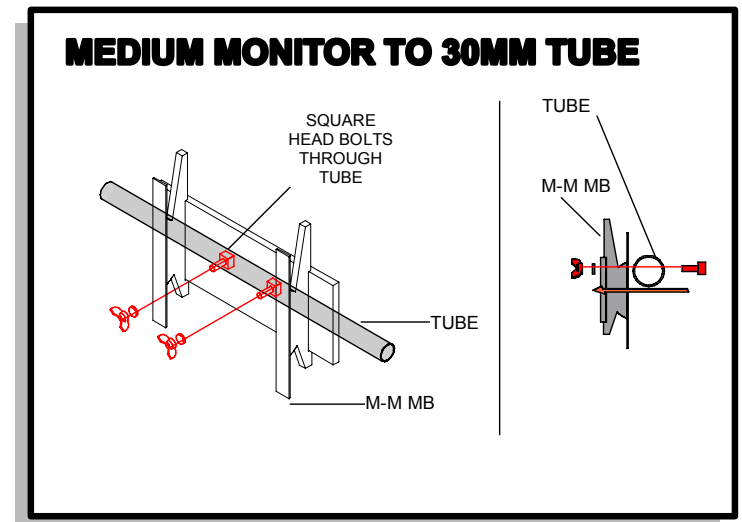
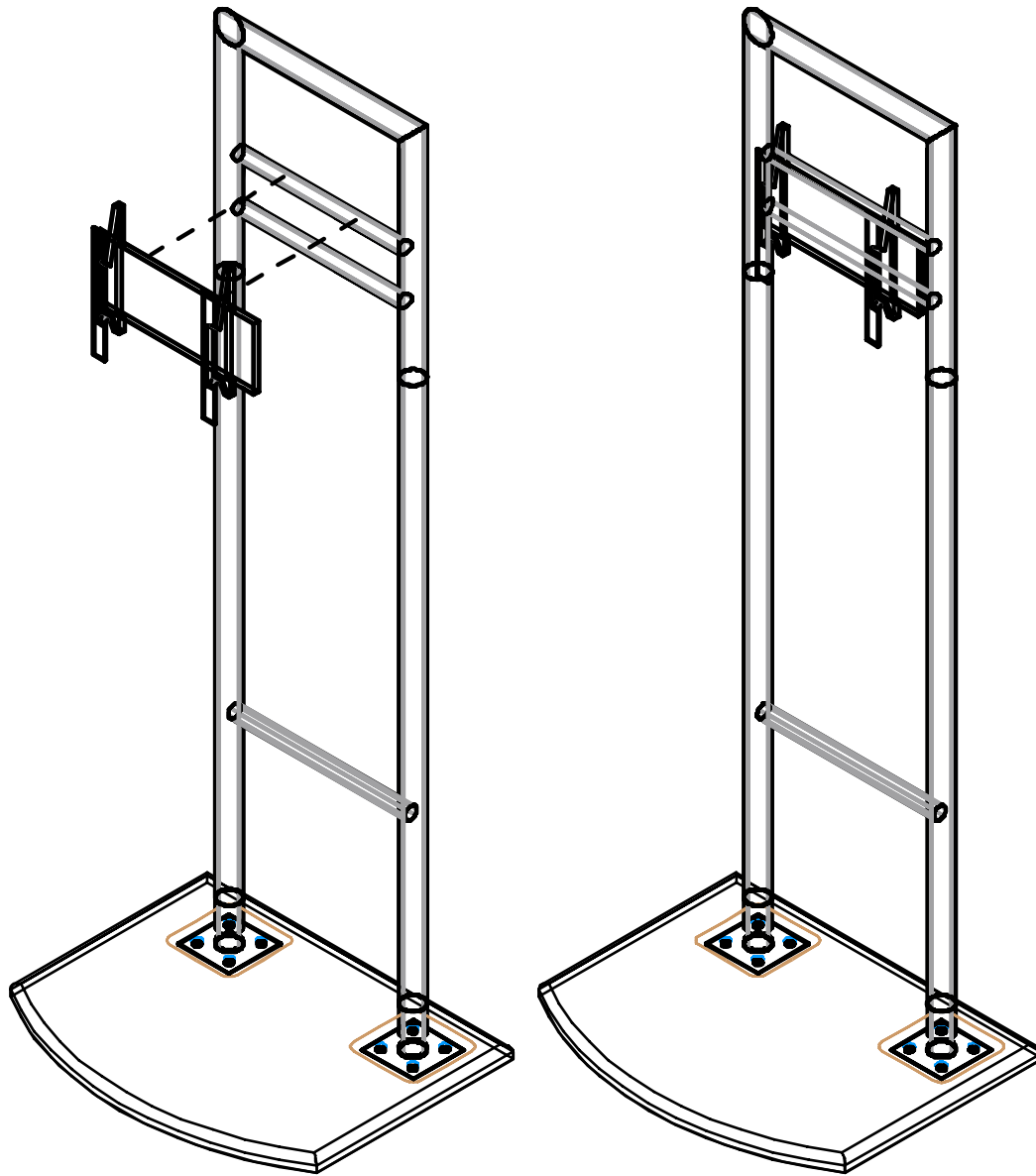



pulse kit 01



pulse kit 02



pulse kit 03



pulse kit 04



pulse kit 05

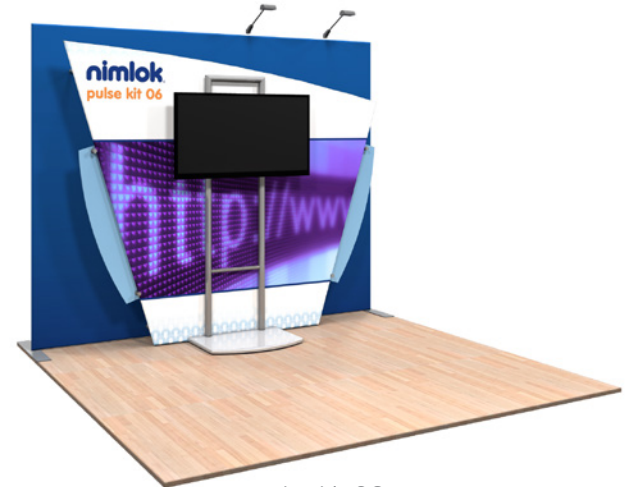

pulse kit 06